

NOTE:
FOR ADDITIONAL GLAZING OPTIONS
SEE HEAVY INTERMEDIATE STEEL WINDOW SECTION.

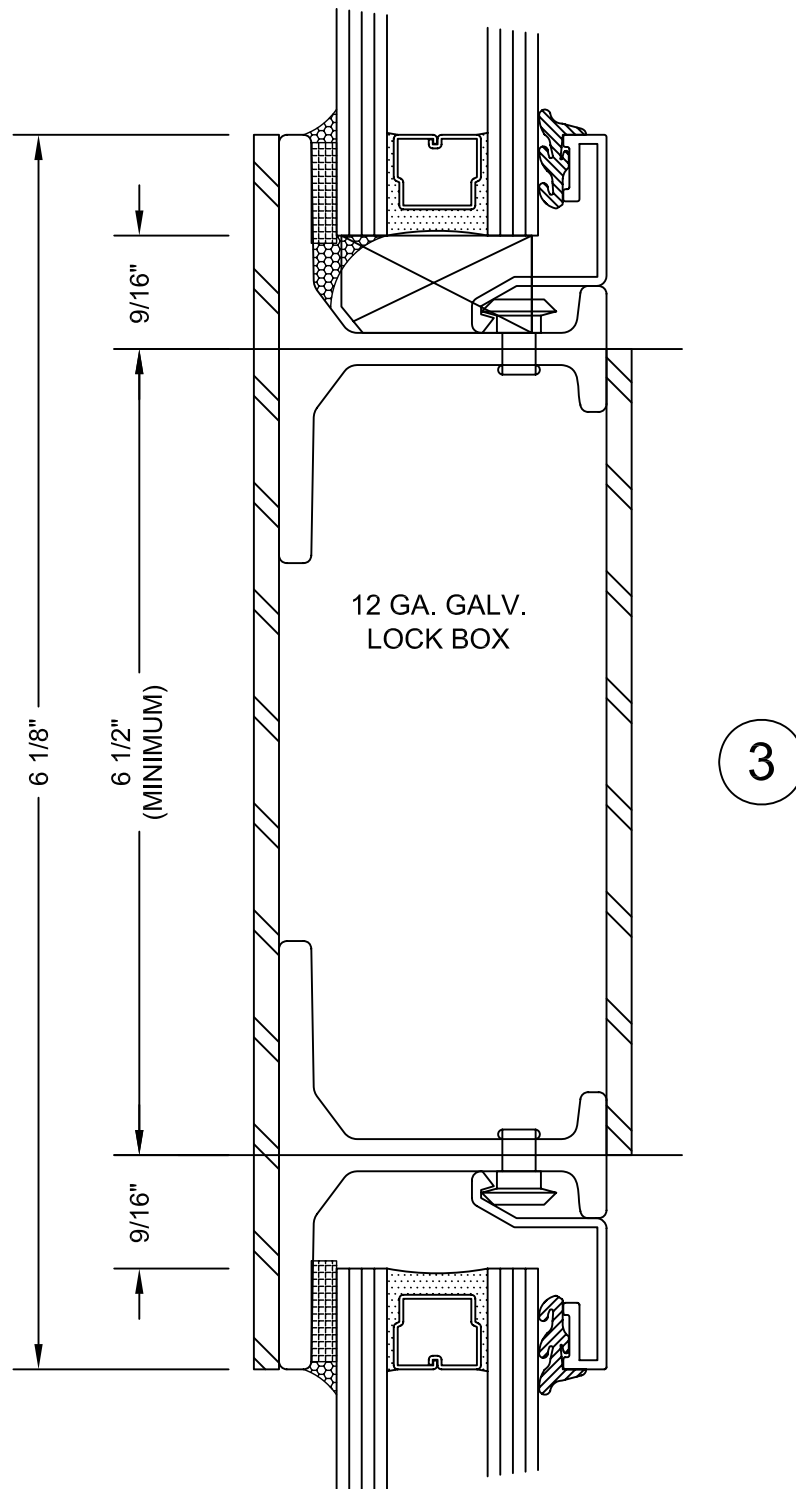

NOTE:
FOR ADDITIONAL GLAZING OPTIONS
SEE HEAVY INTERMEDIATE STEEL WINDOW SECTION.

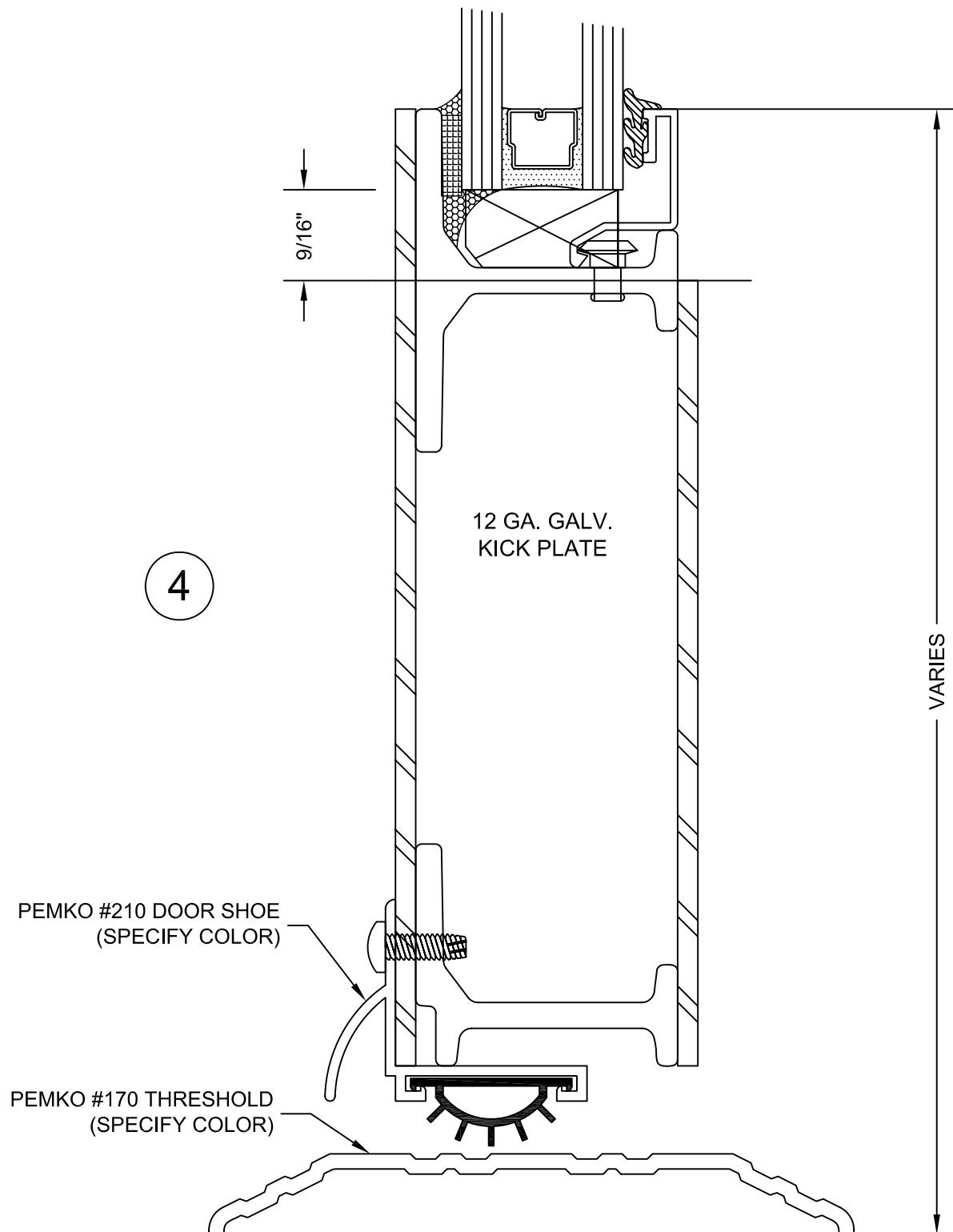

NOTE:
FOR ADDITIONAL GLAZING OPTIONS
SEE HEAVY INTERMEDIATE STEEL WINDOW SECTION.

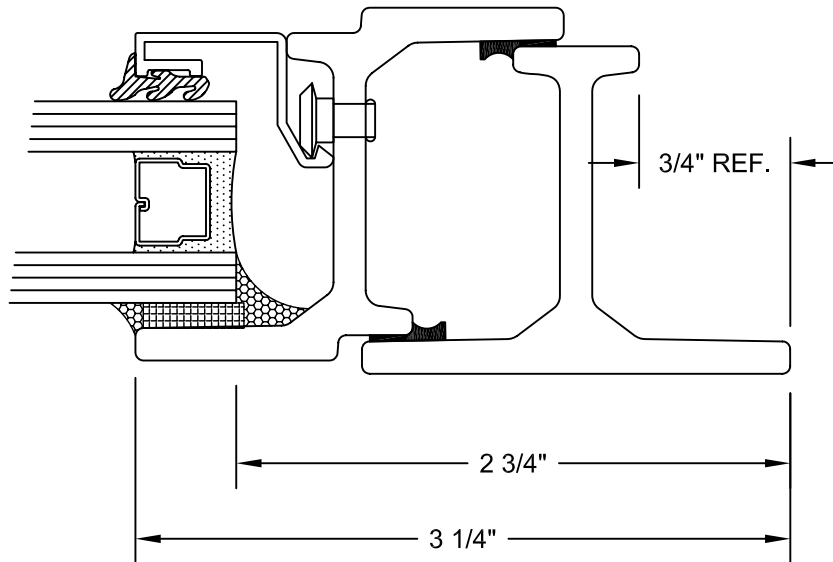

5

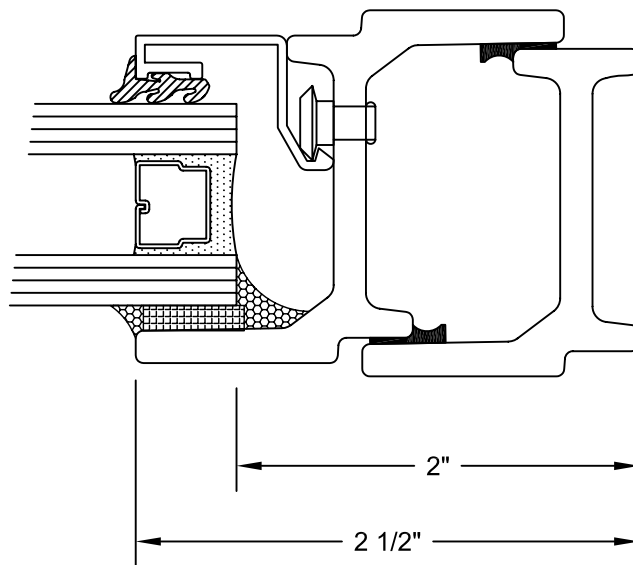

5

NOTE:
FOR ADDITIONAL GLAZING OPTIONS
SEE HEAVY INTERMEDIATE STEEL WINDOW SECTION.

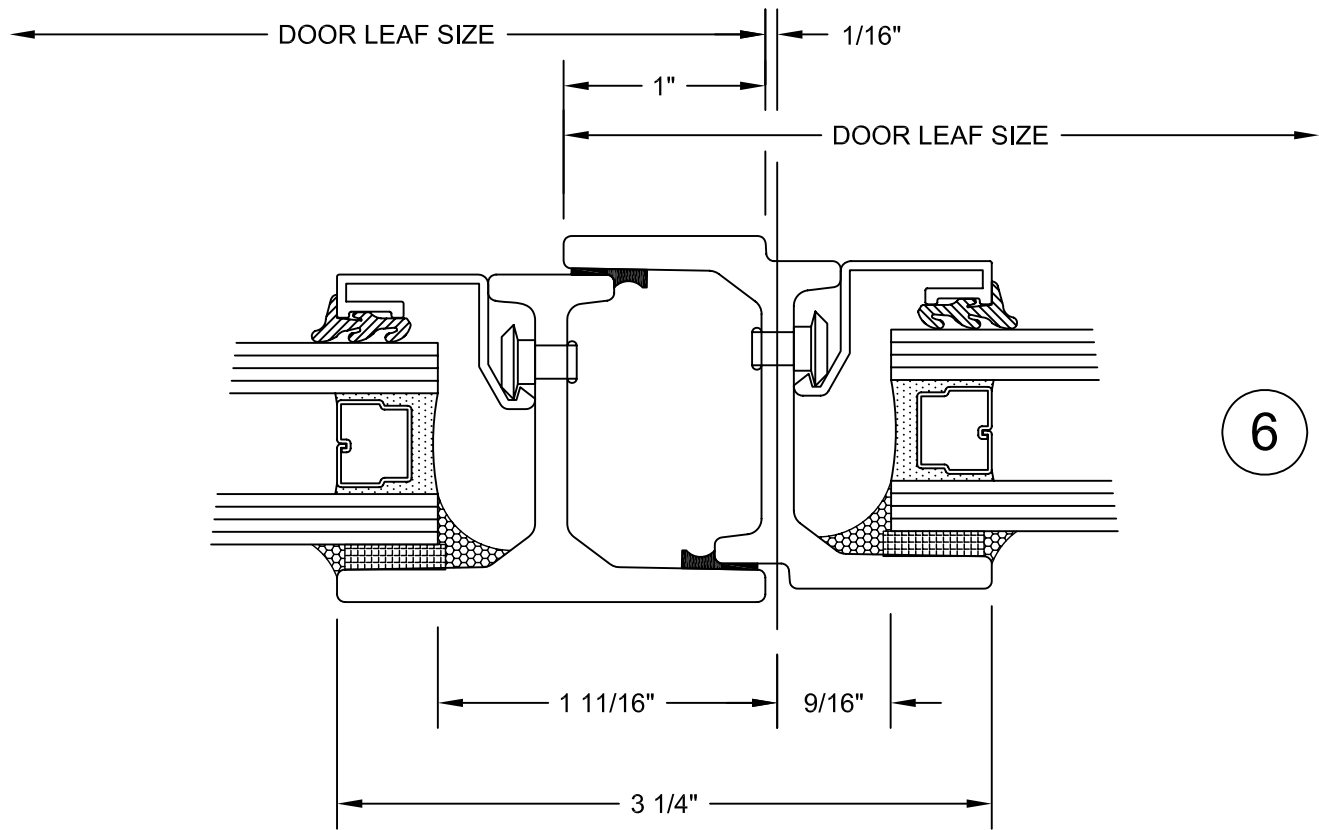

6

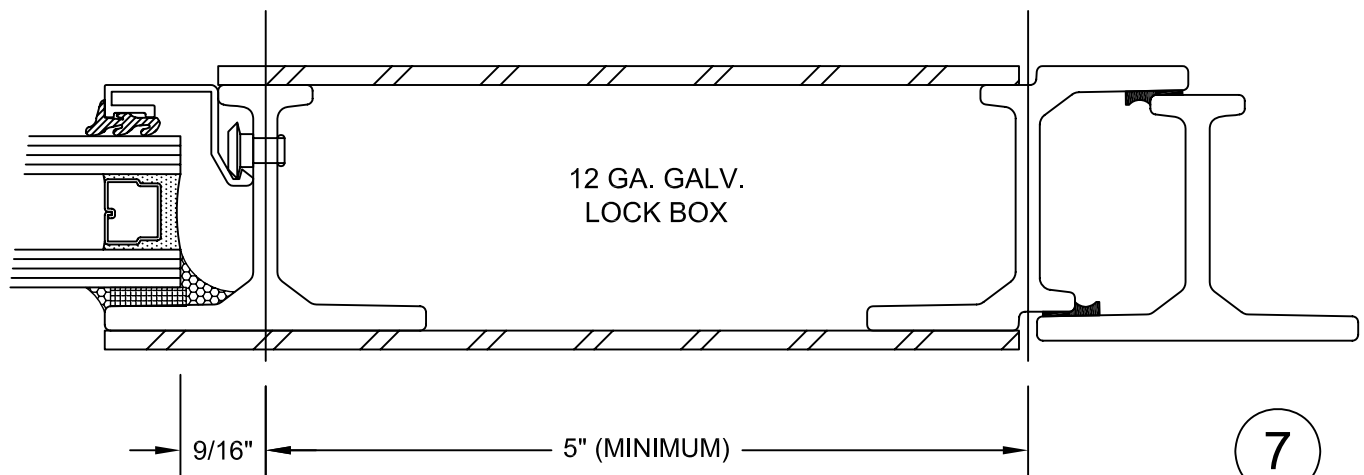

7

SCALE = 3/4 FULL

NOTE:
FOR ADDITIONAL GLAZING OPTIONS
SEE HEAVY INTERMEDIATE STEEL WINDOW SECTION.

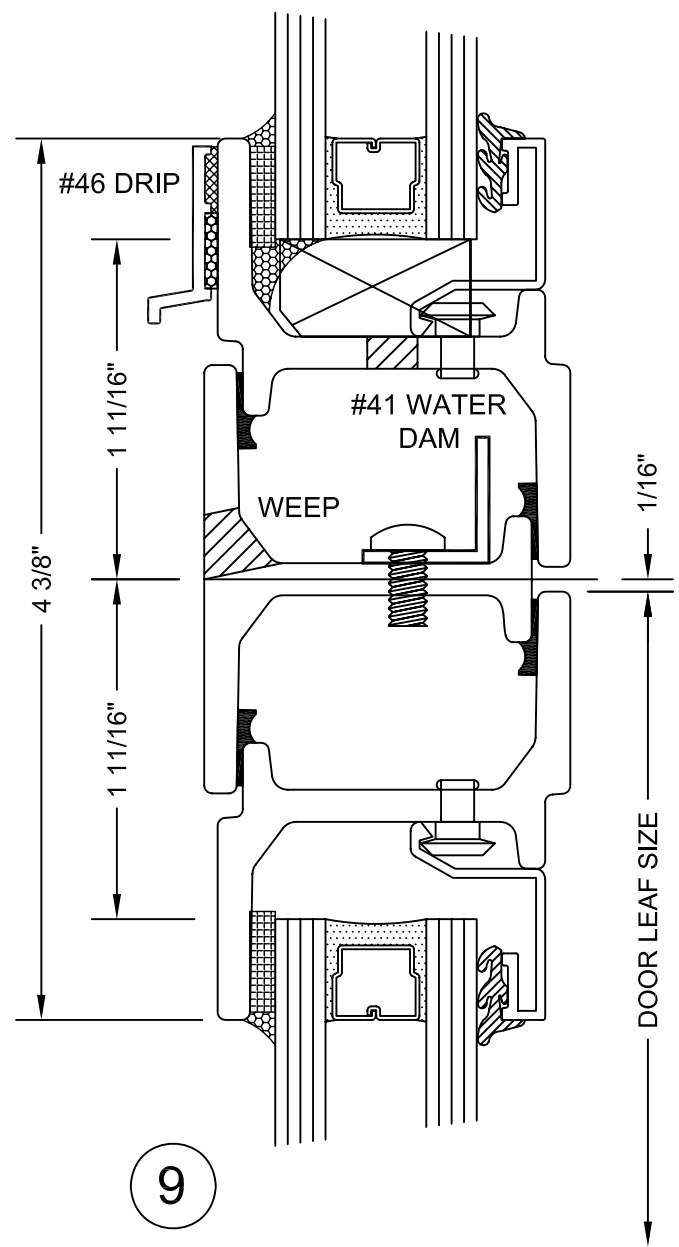
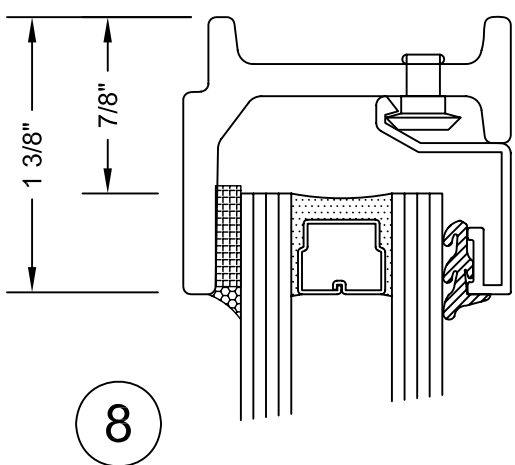
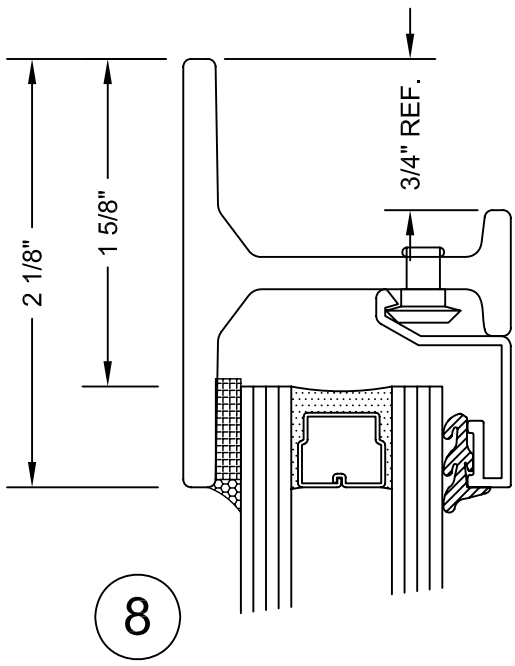

NOTE:
FOR ADDITIONAL GLAZING OPTIONS
SEE HEAVY INTERMEDIATE STEEL WINDOW SECTION.

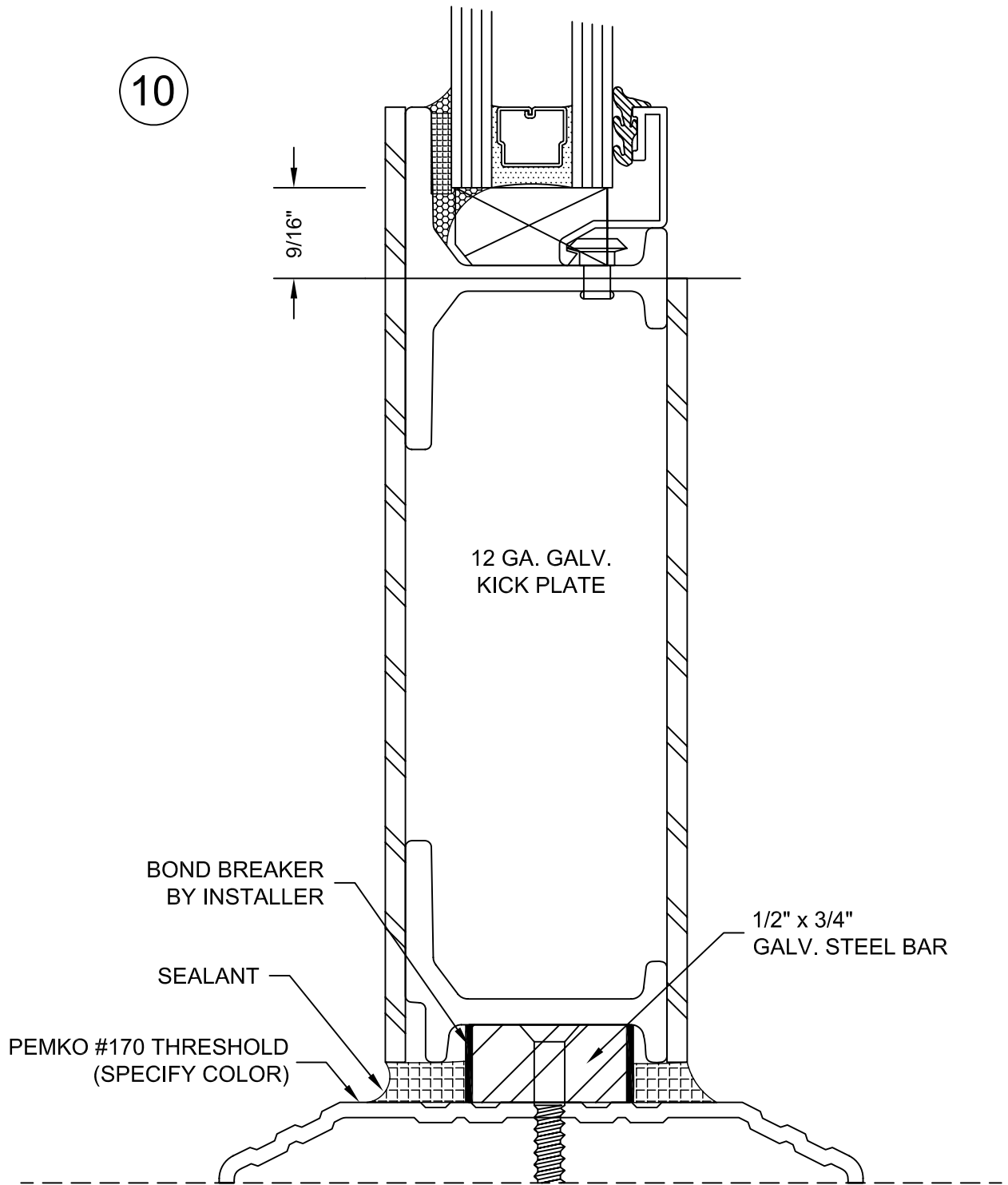

NOTE:
FOR ADDITIONAL GLAZING OPTIONS
SEE HEAVY INTERMEDIATE STEEL WINDOW SECTION.

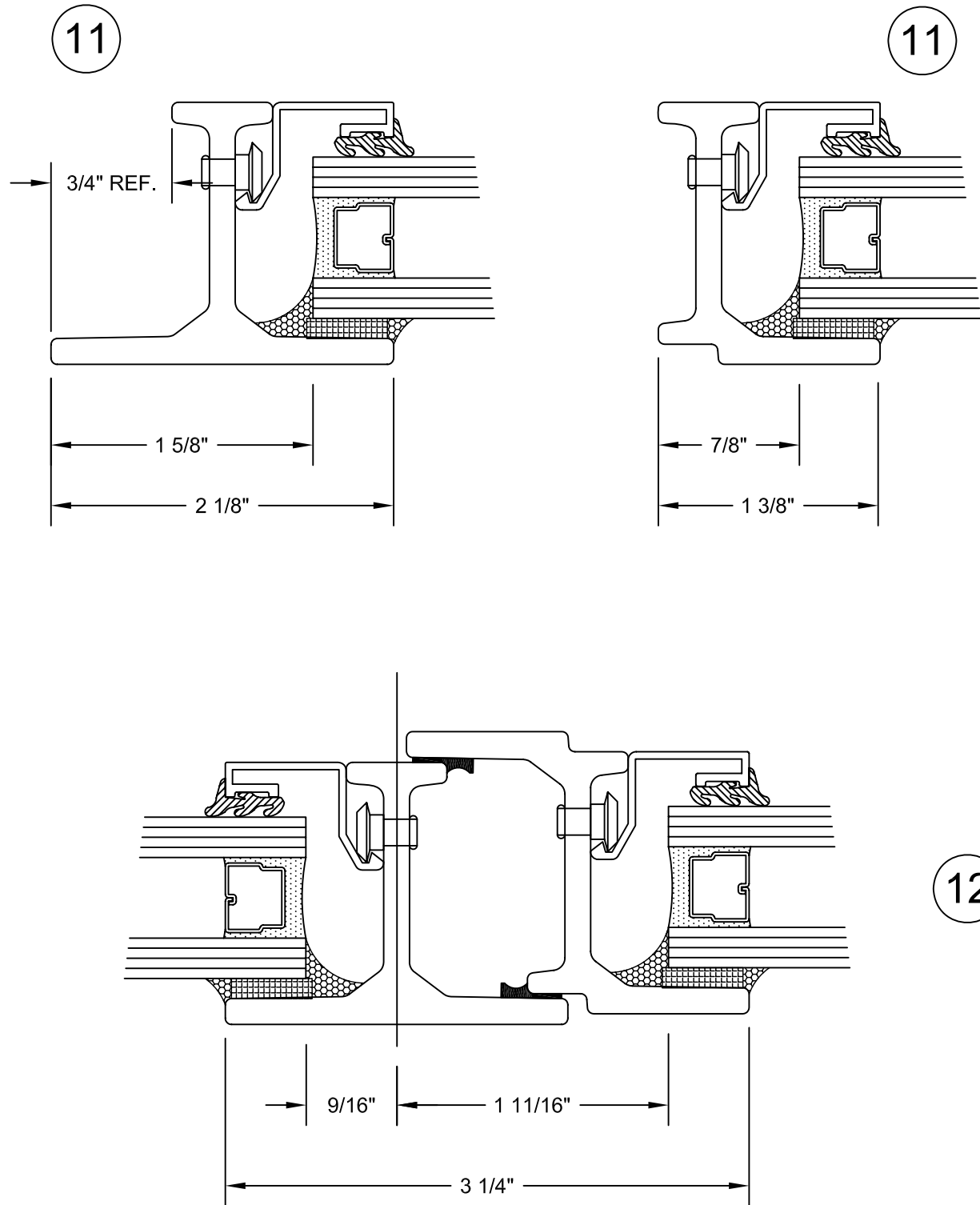

NOTE:
FOR ADDITIONAL GLAZING OPTIONS
SEE HEAVY INTERMEDIATE STEEL WINDOW SECTION.

13

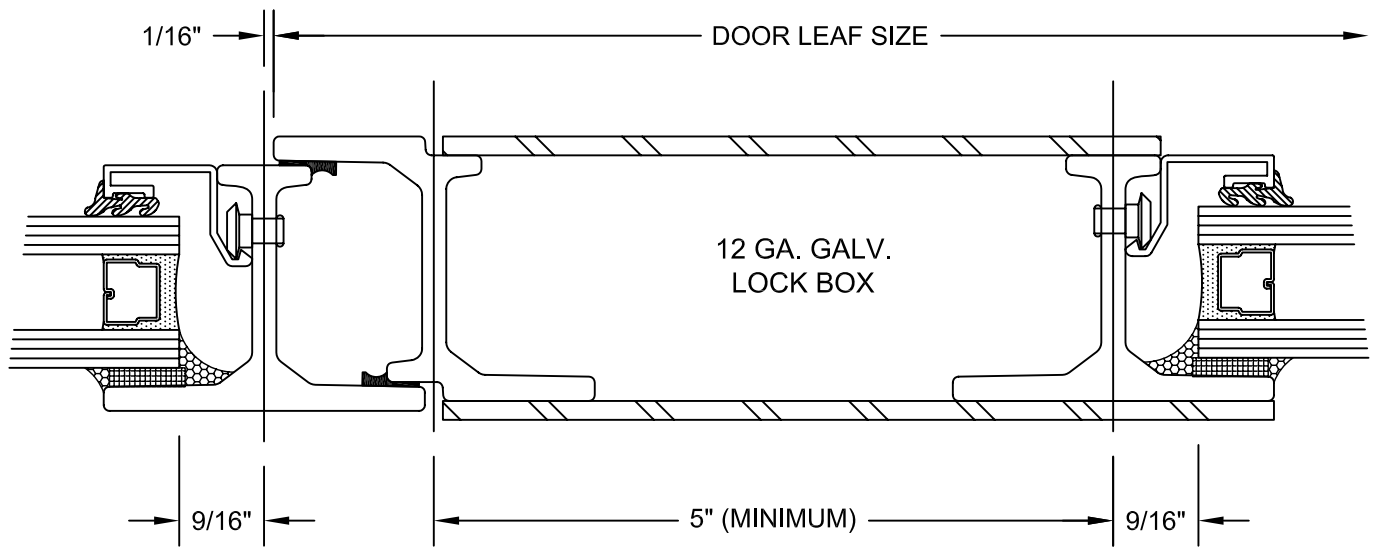

SCALE = 3/4 FULL

NOTE:
FOR ADDITIONAL GLAZING OPTIONS
SEE HEAVY INTERMEDIATE STEEL WINDOW SECTION.